



The *Raymond*[®] Hand Pallet Truck

RAYMOND



- ▶ Heavy-duty construction
- ▶ Smooth, quiet, precise handling
- ▶ Trouble-free operation

Raymond first introduced the hydraulic hand truck — by inventing it in 1929.

Today, Raymond's 75 years of experience continues to produce the finest, most durable hand truck available.

Simplicity and maneuverability make *Raymond* Hand Pallet Trucks the logical choice for use every day, throughout your operation. Heavy-duty construction stands up to the most grueling applications, year after year.

And with so many choices — from varying fork lengths to stainless steel assemblies — you can count on Raymond to deliver a hand truck fit for your use.

RAYMOND[®]
Above. And beyond.[®]

www.raymondcorp.com

Built to last. Easy to own.



Strength for the long haul. The rugged *Raymond*® Hand Pallet Truck is also designed for quick, easy serviceability. Tow bar shoulder support reduces stress on the lower tow bar. Solid steel, fixed pushrods eliminate the need for adjustments. Simplified pump assemblies use fewer parts and feature uniquely packed seals. Pivot points feature brass bushings, and 10 grease fittings simplify the lubrication of all moving parts.



Maximum clearance. The 2.9" lowered height permits easier entry and exit, even into sagging pallets. Entry and exit rollers provide smooth transitions in and out of pallets — and improved control of delicate goods or heavy loads. Variable speed lowering comes standard, reducing the chance of product damage.

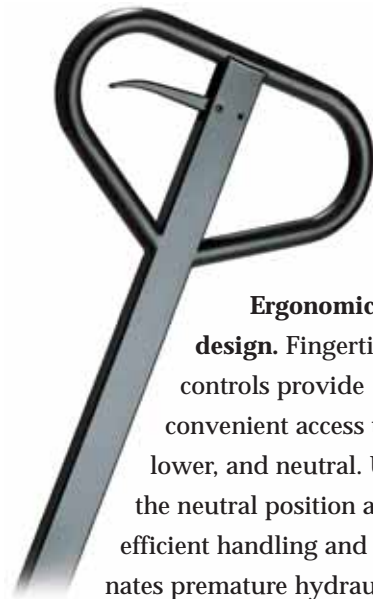

Ergonomic handle design. Fingertip controls provide convenient access to lift, lower, and neutral. Using the neutral position allows efficient handling and eliminates premature hydraulic wear. The handle return spring automatically restores the handle safely to its vertical position. And a full 180 degree steering radius lets you navigate tight quarters.

Options include: Hand brake/parking brake, skid adapter, load backrest, varying fork configurations. Stainless steel construction also available.

Extra Low 2.9" Lowered Height				
MODEL	CAPACITY	A	L	C
RJ50-P	5000 lbs.	27.0"	48.0"	6.2"
<i>Also available in these configurations.</i>		27.0"	42.0"	6.2"
		27.0"	36.0"	6.2"
		20.5"	48.0"	6.2"
		20.5"	42.0"	6.2"
		20.5"	36.0"	6.2"

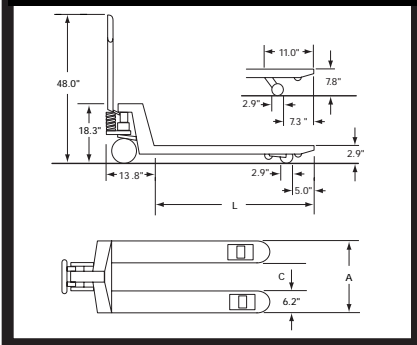

For durability and performance, consider Raymond's complete line of low-lift trucks. Ask your Raymond Dealer for more information today.

RAYMOND
Above. And beyond.®

The Raymond Corporation
P.O. Box 130
Greene, NY 13778-0130
Toll Free 1 (800) 235-7200
Fax 1 (607) 656-9005

www.raymondcorp.com