

# The "S" Series Walkie Stackers



## Raymond® Adjustable Baseleg Walkie Straddle Models RAS20/25

*Raymond® Adjustable Walkie Straddle Models RAS20/25.* Versatility, affordability, and convenience wrapped into one. When you need to maneuver multiple-sized pallets quickly and easily in tight quarters, turn to the *Raymond RAS Stackers*.

These maneuverable staging and dock-to-stock trucks with adjustable baselegs are a versatile, cost-effective solution to pallet handling. Intuitive designs make operator training a breeze. Easy-to-operate ergonomic controls and a transistorized control system provide smooth and precise load handling. Programmable acceleration rates further enhance control of loads in tight, congested work areas—helping to ensure efficient operation.

### RAS20/25 Standard Equipment

- 2000 and 2500 pound maximum capacity
- Full free lift or limited free lift two-stage mast with fork heights up to 143"
- Adjustable straddle baselegs with openings from 35" to 51"
- Reversing switch in handle
- Transistor travel control
- Horn
- Electronic key with password protection
- Hour meter and battery discharge indicator
- 40" high load backrest

**RAYMOND**  
Above. And beyond.®

[www.raymondcorp.com](http://www.raymondcorp.com)

# Specifications—RAS20/25

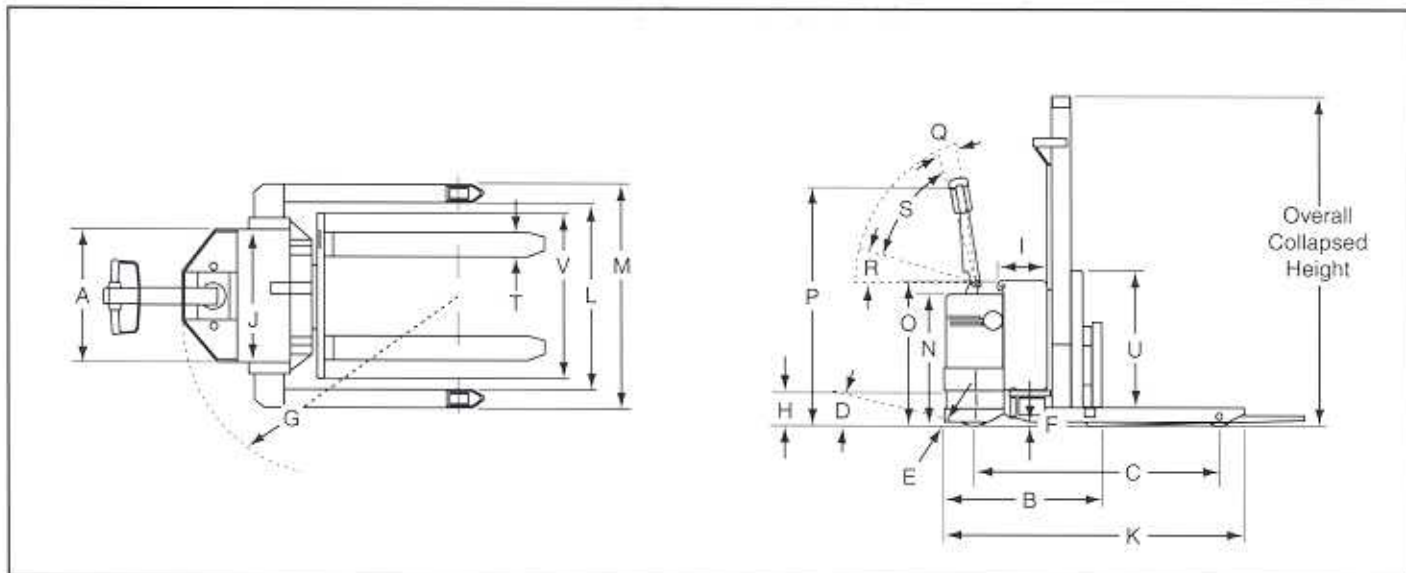

MAST SPECIFICATIONS				
Lift Height LFL (in.)	Lift Height FFL (in.)	Overall Collapsed Height (in.)	Free Lift (in.)	Capacity (lbs.)
2-stage	2-stage			
104		72	4.75	2000/2500
128		84	4.75	2000/2000
143		91	4.75	1600/1600
	104	72	53	2000/2500
	128	84	65	2000/2000
	143	91	72.5	1600/1600

PERFORMANCE SPECIFICATIONS		RAS20/25	
Truck Weight, less battery with 130" mast	lbs.	1560	
Battery Connector		SB-175 red	
Battery Lead Position/Length	in.	8/15	
Battery Voltage	V	24	
Minimum Battery Weight	lbs.	290	
Travel Speed	empty/loaded	mph	3.2/3.3
Lift Speed	empty/loaded	fpm	25/19
Lowering Speed	empty/loaded	fpm	30/37

AISLE WIDTH REQUIRED FOR RIGHT ANGLE STACKING						
RAS20/25						
Load Width (in.)	Load Length (in.)					
	30	36	40	42	44	48
30	63	63	63	63	63	63
36	63	63	63	63	63	63
40	63	63	63	63	63	63
42	68	66	64	63	63	63
44	71	70	69	68	68	67
48	76	76	75	75	75	74

Aisle width requirements based on 4" clearance between pallets.  
Add 6-12" for ease of operation.

Due to continuous product improvements, all terms, conditions and specifications are subject to change without notice. Raymond and Above. And beyond are registered trademarks of The Raymond Corporation. © 2002 The Raymond Corporation, Greene, NY. Printed in USA. SIFB-0050 80026-13

DIMENSION CHART		
	RAS20/25	
Capacity	lbs.	2000/2500
A. Tractor Width	in.	31.5
B. Tractor Head Length	in.	31.7
C. Wheelbase	in.	52.4
D. Grade Clearance	n/a	n/a
E. Underclearance: Tractor	in.	1.6
F. Underclearance: Baselegs	in.	1.6
G. Turning Radius*	in.	59.8
H. Battery Floor Height*	in.	6.5
I. Battery Compartment Width	in.	8.75
J. Battery Compartment Length	in.	27.375
K. Overall Length (w/o forks)	in.	63.75
L. Baseleg Opening (inside)**	in.	35-51
M. Baseleg (outside)	in.	43-59
N. Tractor Height at Handle	in.	28.4
O. Tractor Height at Battery	in.	31
P. Handle Height Retracted	in.	53.7
Q. Top Vertical Braking Arc	deg.	20
R. Bottom Braking Arc	deg.	5
S. Handle Operating Arc	deg.	60
T. Forks	in.	1.75 x 4
U. Load Backrest (height)	in.	40
V. Fork Adjustment	in.	10 - 31.5
Drive Tire	in.	8.5 x 2.75 polyurethane
Load Wheels	in.	4 x 3 polyurethane

\* Battery compartment is not available with rollers, battery must be placed in or removed from compartment using an overhead lift or crane.

\*\* Adjustable.

**RAYMOND**  
Above. And beyond.®

The Raymond Corporation  
P.O. Box 130  
Greene, New York 13778-0130  
Toll free 1 (800) 235-7200  
Fax 1 (607) 656-9005

www.raymondcorp.com